

Data Sheet



COMPRESSION LOAD CELL

MODEL ELC-210S

INTRODUCTION

The Encardio-rite model ELC-210S is a heavy duty precision load cell. Specially designed to meet the increasing demand in load measurement with a high degree of accuracy and reliability, the load cell is ideally suited for measurement of compressive load or forces in struts application. The load cell is available in capacities ranging from 1000 kN to 3500 kN.



FEATURES

- Rugged & robust construction
- Outstanding reliability and long term stability
- Specially designed to suit harsh & severe industrial environment
- Temperature compensated
- Stable system with no moving parts and linkages
- Bridge resistance 770 ohms
- Any standard strain gage bridge measuring read-out device can be used
- Side and eccentric load effect negligible
- Hermetically sealed by electron beam welding

DESCRIPTION

The internal construction of the load cell is columnar. The element of the load cell is made of martensitic stainless steel. The element is hardened to give better linearity and hysteresis. The strain gages used is of foil type and are bonded to the elements using special epoxy cements which are very reliable.

OPERATING PRINCIPLE

The electron beam welded sensor utilizes precision bonded foil strain gages connected in a simple Wheatstone bridge circuit. The output is derived from imbalances in the bridge circuit as load is sensed by the sensor. Typically the bridge circuit is excited by 10 VDC to give a full scale output of around 1.5 mV/V.

Load applied to the cell can be measured by using any standard digital read-out unit suitable for resistive strain gage type sensors. The data can also be automatically collected at desired frequency, stored and transmitted to remote server by a suitable datalogger using multiplexer/busmux or SDI-12 digital interface.

EXCELLENCE IN DESIGN

Load cells have great resistance to extraneous forces. This increases the fatigue life, permits less stringent mounting

APPLICATION

- Measurement of compressive load
- Measurement of axial forces in struts.
- Load testing in piles.
- Other such load measurement applications

alignment and reduces the possibility of reading error. The load cell is protected against dust, moisture and adverse environmental conditions.

SPECIFICATION

Type	Resistive strain gage
Range (kN)	1000, 1500, 2000, 3000, 3500
Over range capacity	150 %
Non linearity	± 1 % fs
Output	1.5 mV/V ± 10 %
Excitation	10 V DC (maximum 20 VDC)
Terminal resistance	
Input	770 Ohm ± 5 %
Output	700 Ohm ± 1 %
Temperature limit	-20 to 80°C
Cable connection	Four core shielded 2 m long

DIMENSION

Mounting in strut application

	Compression load cell
Capacity kN	A mm
1000/1500	234
2000/2500/3500	260

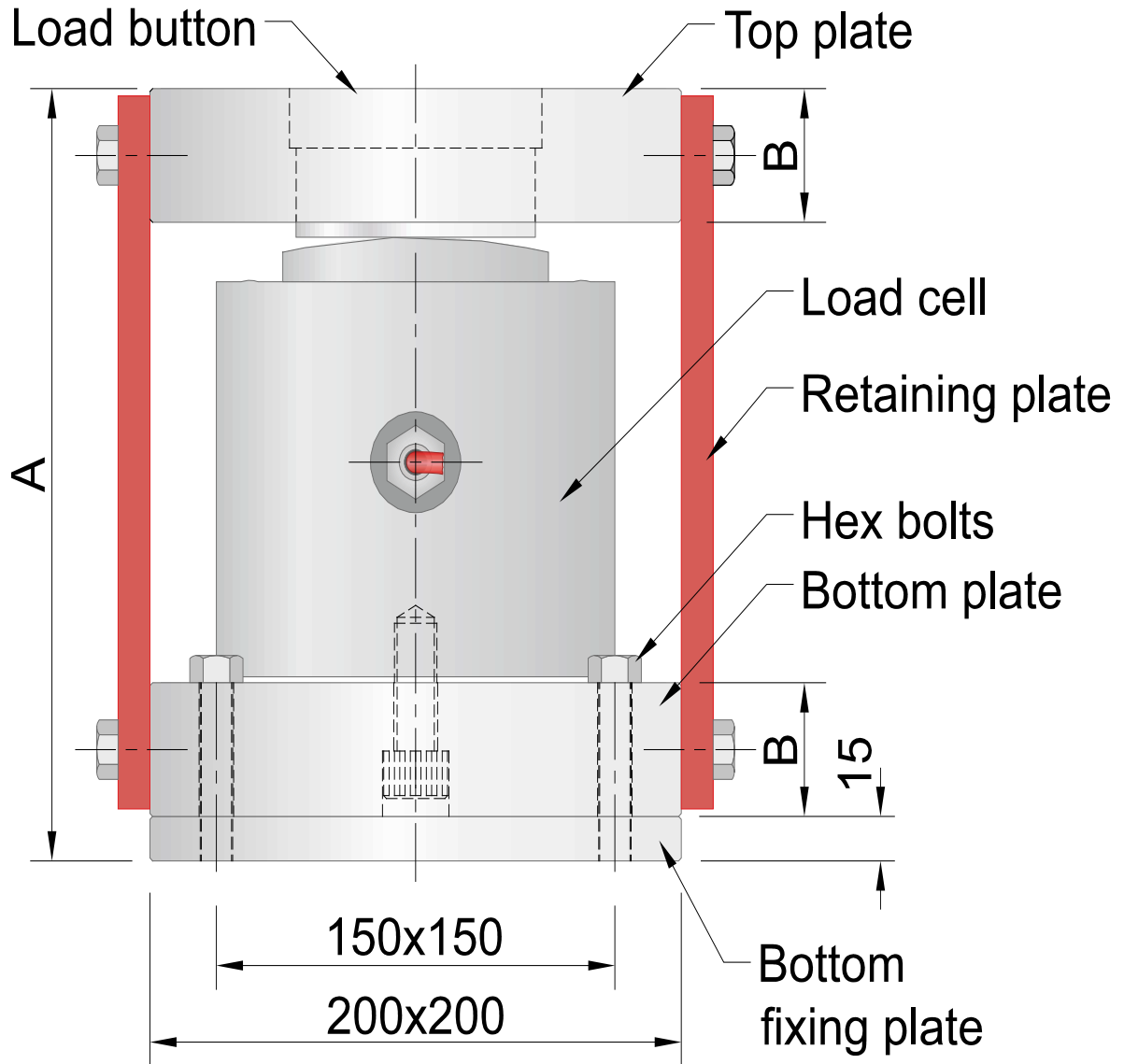

ORDERING INFORMATION

Model ELC-210S- X

Capacity kN _____

*All specifications are subject to change without prior notice

DATASHEET | 1182-12 R02



TUNNELS



HYDROELECTRIC



CONSTRUCTION



STRUCTURAL



METRO & RAIL



BRIDGES



MINING

Encardio-Rite Group - India | Bhutan | Bahrain | Qatar | Saudi Arabia | UAE | Greece | Spain | UK | USA